

Auto Sens – Contactless throttle pedal sensor assembly -Installation instructions

Thank you for purchasing a contact-less throttle position sensor, for your Maserati 3200 GT

The sensor is a direct replacement for the manufacturers Bosch part and is both mechanically and electrically compatible with the original part, and should drop fit into your car seamlessly.

The complete unit is shown here.

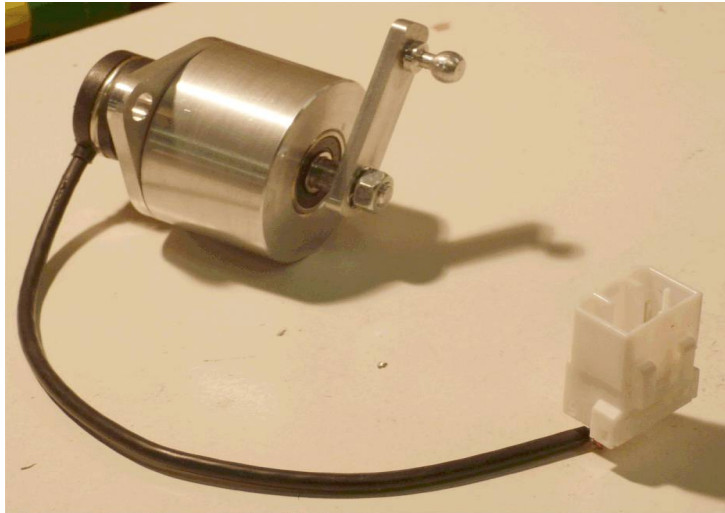

As you can see it comes complete with a lever arm and electrical connector so it is a plug in fit, requiring no wiring or mechanical modifications.

To replace your existing unit with this one you require to carry out the following procedure

1. Remove the existing sensor, including bracket.
2. Fit the new sensor to the mounting bracket
3. Fit the new sensor to the car
4. Perform a quick set up measurement
5. Perform calibration procedure

There are two sections here the first is the normal installation which in most cases is all you will need. In some cases where there have been adjustments made to the pedal position end stop bolts, usually to try and alter the idle speed, and also where the cars wiring has been modified you may need a more advanced installation procedure and this is included in section 2.0.

I have also made copies of the Maserati workshop manual that refers to this pedal sensor.

Note that the cars idle speed of 1000 rpm is hard coded into the ECU and cannot be adjusted using the pedal sensor or indeed the throttle body. Also full throttle is controlled by the voltage that you calibrate into the ECU at the end of this procedure. So the only way to get the best out of your car is to make sure this sensor is set up according to the maserati specification and make sure it stays that way.

This contactless pedal sensor should maintain its output and calibration indefinitely once set up and should provide optimal operation of your 3200 GT without any need for further adjustment, as unlike the original unit this one will not wear out or age in any noticeable way.

I built this unit initially to remove this issue from my own car which had needed a pedal sensor replacement after only 3 years, and I was sure I could do better. I have been running this type of sensor on my car for over 8 years now and often test the new units on my car before shipping. I hope this unit is something you fit and never think about again, that's what I planned anyway. Take your time setting it up and it should serve you well.

Section 1.0 – Normal installation

To remove the existing sensor, disconnect the electrical connector by pressing the retaining button on the body and pulling the two halves apart.

There is a linkage arm which is push fit onto the ball on the end of the sensor lever arm

I couldn't get a picture of this lever in place! However it's the bit that goes over this ball! This can be quite stubborn but don't be disheartened it does just pull off. It is sometimes easier to remove the two bolts and then disconnect the ball coupling.



You can try to remove the two bolts which hold the sensor in place but these are only accessed from above and I think this is too difficult. I prefer to remove the complete mounting bracket by removing the two bolts on the back of the bracket, on the bulkhead.



These are quite difficult to get at with the original Bosch sensor but much more accessible with your new transducer as it is smaller, so

fitting is easier than removal.

Don't lose the shims which will fall out once you have these bolts removed.

You should now be able to easily remove the sensor unit from the car.

Next remove the two bolts holding the sensor to the mounting bracket and mount the new sensor in place making sure to get the lever the same way as the old unit (you have two choices!)

The photo shows the correct mounting position (in case you forgot to note it!)

Replacing the shims you removed fit the new sensor in the reverse procedure.

WARNING

The moment in this process that you connect the small mechanical lever arm to the sensor is very critical. The sensor has an internal end stop to prevent the arm from rotating all the way round on the spring. The pedal assembly also has an end stop which is controlled by a large bolt on the pedal assembly. Once fitted and set up the pedal **must** rest in the idle position on the large bolt and not the internal stop in the sensor. So when you connect the lever assembly you should be moving the sensor slightly in the correct direction (off its internal end stop) to make it fit to the pedal assembly. If when you go to push the lever onto the sensor it does not fit and you cannot make it connect by rotating it in the correct direction STOP, do not force the sensor arm to make it fit this will damage the new sensor.

If this is happening you need to loosen the end stop bolt on the pedal assembly and adjust it until the lever can be connected without forcing the new sensor lever back against its end stop. Ideally to connect the lever you should be rotating it slightly in the correct direction (5-10 degrees)

If you have a problem at this point refer to the second section here on problematic cars, they are hand build in Italy so they are not all the same!!!



Your sensor should now be fitted as shown here

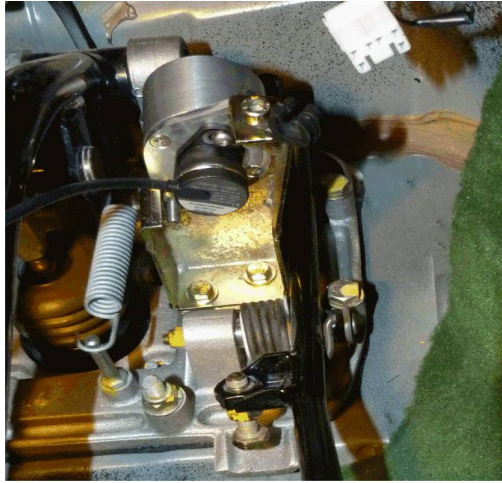

To make sure your sensor output is exactly as per the Maserati specification you will need a volt meter. By touching the contacts through the back of the connector shell measure between the black wire (0v) and either the yellow (output1) or white (output2) wires. These are the two sensor position outputs from the transducer.

You will need to switch the ignition on to get voltage readings.

With the pedal at idle (i.e. don't touch it) you should have between .350v and 0.6v (aim for close to .35)

Press the pedal to its end stop

You should have between 2.9 and 3.7 volts (3.1 to 3.3 appears to be preferable)

If your sensor is outside these limits. Then follow this procedure

With the pedal in the idle position slacken the two small screws holding the black sensor. Rotate the sensor body gently until the voltage is between the limits for the idle setting.

Now press the pedal to the full throttle position and measure the output again, if this is not within limits using the large end stop bolt on the pedal assembly adjust this until the sensor output is within limits.

The final part of this process is to run the Maserati calibration procedure.

It is in the manual, and I have included a copy, but goes like this

Idle calibration - switch on the ignition with the gear lever in neutral, do not start the engine. Leave the ignition on for 2 minutes & 10 seconds. Switch off. Complete

Full throttle calibration- switch on the ignition with the gear lever in neutral, do not start the engine. Press the pedal to full throttle position for 12 seconds. Switch off. Complete

Both the sensor and the ecu change a little with temperature and I have occasionally seen problems when the calibration is carried out either when the car is very hot or very cold that there are problems when it warms up/cool down. So its always a good idea to perform the calibration when the car is at a normal temperature for where you live.

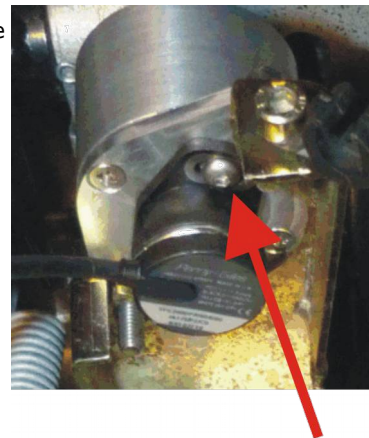

Section 2.0 Detailed procedure for installing the replacement Pedal sensor, when the existing mechanical setup is suspect.

This procedure is to be followed if you have had problems getting the new sensor set up or indeed if the new sensors have been damaged by the act of installation.

A) Explanation

The pedal sensor setup in the Maserati 3200 (and 4200) is typical of this type of car and is set up by hand. This in turn means that by messing around with it you can set it up all wrong and get into a situation where it's difficult to work out how to get it back into a correct set up again.

The pedal sensor is quite simple, it measures the position of the pedal over a fairly short range of rotary movement. The pedal sensor is mounted to a solid metal bracket so the pedal mechanism has to move over the correct range of rotation for the sensor to work properly. If the mechanical position of the pedal is trying to move beyond the upper or lower measurement range of the sensor, then this will cause problems and in extreme cases can cause damage to the sensor if you are not careful.

B) Procedure.

Initial mechanical set up.

There are two bolts that determine the maximum throttle position and the idle position of the pedal. These are on the pedal lever itself.

If you are not sure about the set up on your car then the best way to proceed is to loosen the lock nuts on these two adjustment bolts and adjust the positions to first raise the idle position of the pedal (pedal is higher than it was) and adjust it way up from where it was, I would suggest adjust it as far as it will go. Do the same with the full throttle position, loosen the lock nut and adjust it to restrict the full throttle position so it will not travel as far as it was doing before, again adjust the bolt as far as it will go.

Pre install electrical check

With the ignition on, using a volt meter verify that you have 5V DC between the red and grey wires on the right of this photo (this is the side of the connector on the car loom)

Also try an ohm reading between the pin connected to the grey wire in the top right of this picture and the car body, and make sure that is a low ohm reading. This should be done with the ignition off.



Install the sensor as directed.

With the ignition on and the engine not running measure the voltage from either out 1 or out 2 to 0v or gnd.

This should be higher than 0.4 volts DC and less than 3 volts. If it is lower than 0.3 volts you have a serious problem, or you have not adjusted the end stop bolts to their highest position, as described in the previous step.

Now adjust the idle position bolt on the lever mechanism until this voltage reads between 0.35 and 0.65 volts. So aim for 0.4 to 0.45 volts. Once you have the correct voltage tighten the lock nut and make sure the voltage is still between 0.35 and 0.65volts. Make sure that both out 1 and out 2 are both the same and within 15mV of

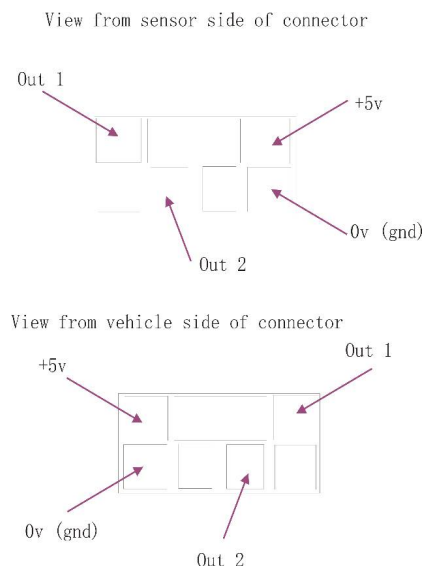

each other (0.015v). Try operating the pedal mechanism a few times and make sure it always comes back to the same voltage.

Now measuring the same voltage out, press the pedal to the floor (hitting the end stop bolt) and this voltage should be below 3.5 volts. Adjust the end stop bolt until this reads around 3.3v or at least above 2.9 volts which is the lower limit.

Again tighten the lock nut and verify the voltage is still within limits. Make sure both outputs are the same although the tight difference restriction appears only to apply at idle.

So now your pedal sensor should create a smooth changing voltage from 0.4 volts to 3v or more as you press the pedal. Both outputs should read the same, and at idle the two outputs must be very close together.

If all of this is true then you can run the pedal sensor calibration as outlined in the manual, and this should work.

Some notes on this procedure

- Be careful when making contact with the pins on the connectors. The safest thing to use is meter probes with thin probe tips that can be pushed into the connector shell to make contact with the pin.
- It can also make your life easier if you have a croc clip on the zero volt lead on your meter and just clip this to a local piece of the metalwork of the car.
- If you do not have the connectors present, and your car is hard wired, you need to be very careful with bare wires. If you touch the 5v supply from the ECU to the car body you risk damaging the ECU so this should be avoided. If you touch either of the output wires to the 5v or indeed the main 12v power for the car, then you risk damaging the ECU and the sensor, and so this must also be avoided.
- It is worth noting that given the cars sensitivity to the position of the pedal at the idle position it is worth making sure that the carpet and indeed anything else in this area does not come in contact with the pedal mechanism, as this can cause errors.
- If you are fitting one of my contactless sensors then the biggest risk of damage is the zero end, end stop. If your pedal mechanism is set mechanically so that, at idle the sensor is hitting this end stop, and you force it to the position the pedal wants to return to this can break the end stop mechanism inside the sensor. So the only way to check for this is to be very careful at the point you connect the lever with the two ball joints that links the pedal mechanism to the sensor lever. If when this is connected the pedal mechanism does not hit the end stop bolt then the end stop bolt is set way too low. Do not push the pedal down to make the end stop bolt land this will just break the end stop inside the sensor or force the level mechanism to move from its correct position. The only solution is to raise the bolt position until the sensor lever starts to move.
- It is worth noting that no amount of moving this around will change the performance of the car. The only thing that will make your car work properly is if it's set up within limits and the calibration is done, that's it. No tweaking of bolts or bending things will make it work better.
- The only thing that affect performance is full throttle. And so as long as your pedal mechanism reliably generates the voltage you have calibrated into the system as full throttle you will get full throttle. The contact less sensor I have built should mean that this voltage remains constant throughout the life of the car maintaining peak performance.
- The greatest source of engine warning lights (CEL's) is the idle output from the sensor. This is generally due to a very small change in the output of one of the two sensor outputs, making the two outputs different. There is a "fix" where the two outputs are connected together and this does remove the error. It does however remove the safety aspect of having two outputs that have to both produce a full throttle demand before the engine will open up. The contact less sensor retains the full dual output system as defined for this Maserati system.
- The change in the sensor output that causes the error, can be wear in the sensor or poor connection in the sensor wiring or connector. So it is always a good idea to ensure the connections and wiring all are in good condition at the same time you are replacing the pedal sensor.

ACCELERATOR PEDAL POSITION SENSOR

Removal-Installation

Proceed as follows:

- disconnect the electric connector (2) of the sensor (1) (Fig. 139);
- remove the tie-rod (3) connecting to the accelerator pedal;
- remove the sensor loosening the two fastening screws (arrow).

Install reversing the procedure followed for removal.

Fig. 139 ▼

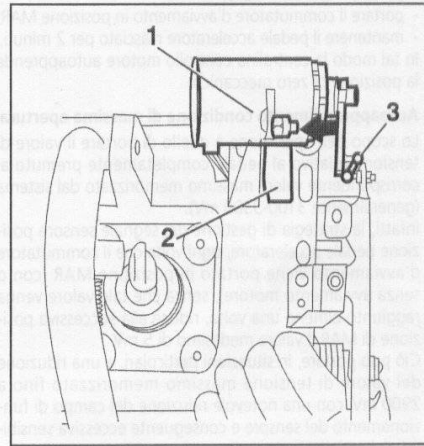

Adjustment

The engine control unit possesses a self-adapting procedure for reading the signal from the accelerator pedal position sensor.

It is however a good rule to check that the voltage ratings in the two extreme positions are within the respective ranges:

- pedal released: 350 to 600 mV;
- pedal pressed: 2900 to 3700 mV.

In addition, when replacing the sensor, or when the driver notes particular sensitivity of the accelerator pedal to controls ("nervous" pedal), it is necessary to run a manual teaching procedure.

Idle speed conditions

The procedure is carried out as follows:

- put the gear lever in Neutral;
- move the ignition switch to the MAR position;
- keep the accelerator pedal released for 2 minutes.

This way the engine control unit automatically learns the mechanical zero position.

Fully open condition

The purpose of this operation is to take the voltage rating associated with the pedal completely pressed to the corresponding maximum value memorised by the system (generally 3100-3300 mV).

In fact, each time the ignition switch is moved to MAR (with or without starting the engine), without reaching this rating at least once, the accelerator pedal position sensor signal management strategy reduces the value by 5 mV the next time the ignition switch is moved to MAR. Under particular circumstances, this can lead to a reduction of the maximum voltage memorised down to 2900 mV, with a considerable reduction of the sensor operating field resulting in excessive sensitivity of the pedal to the controls.

The procedure is carried out as follows:

- put the gear lever in Neutral;
- move the ignition switch to the MAR position;
- press the accelerator pedal down completely and keep that position for 5 seconds;
- release the pedal.

This way the engine control unit resets the maximum rating memorised by the system (generally 3100-3300 mV).

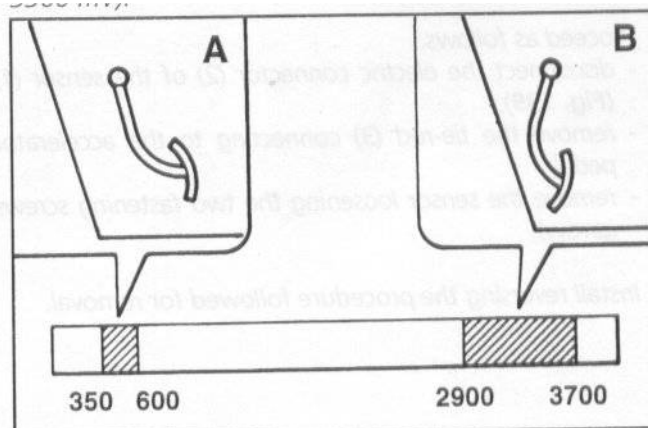

Fig. 140 ▲

- A. Permissible voltage range for pedal released
- B. Permissible voltage range for pedal pressed completely

